



LCD MODULE SPECIFICATION

Customer: _____
Model Name: HC018TR50023-A88
Date: 2020/10/11
Version: V0

- Preliminary Specification
 Final Specification

For Customer's Acceptance

Approved by	Comment

Approved by	Reviewed by	Prepared by

Table Of Contents

List	Description	Page No.
	Cover	1
	Revision Record	2
	Table Of Contents	3
1	General Information	4
2	External Dimensions	5
3	Interface Description	6
4	Absolute Maximum Ratings	6
5	Electrical Characteristics	7
6	Timing Characteristics	7
7	Backlight Characteristics	8
8	Optical Characteristics	9
9	Reliability Test Conditions And Methods	11
10	Inspection Standard	12
11	Handling Precautions	15
12	Precaution For Use	16
13	Packing Method	16

1. General Information

ITEM	STANDARD VALUES	UNITS
LCD type	1.77" TFT	--
Dot arrangement	128(RGB)×160	dots
Color filter array	RGB vertical stripe	--
Display mode	TN / Transmissive / Normally White	--
Viewing Direction	6 o'clock	--
Gray Scale Inversion direction	12 o'clock	--
Driver IC	ST7735S	--
Module size	34.7(W)×46.7(H)×2.3(T)	mm
Active area	28.032(W)×35.04(H)	mm
Dot pitch	0.219(W)×0.219(H)	mm
Interface	8-bit 8080-series system interface	--
Operating temperature	-20 ~ +70	°C
Storage temperature	-30 ~ +80	°C
Back Light	2pcs White LED	--
Weight	TBD	g

2. External Dimensions

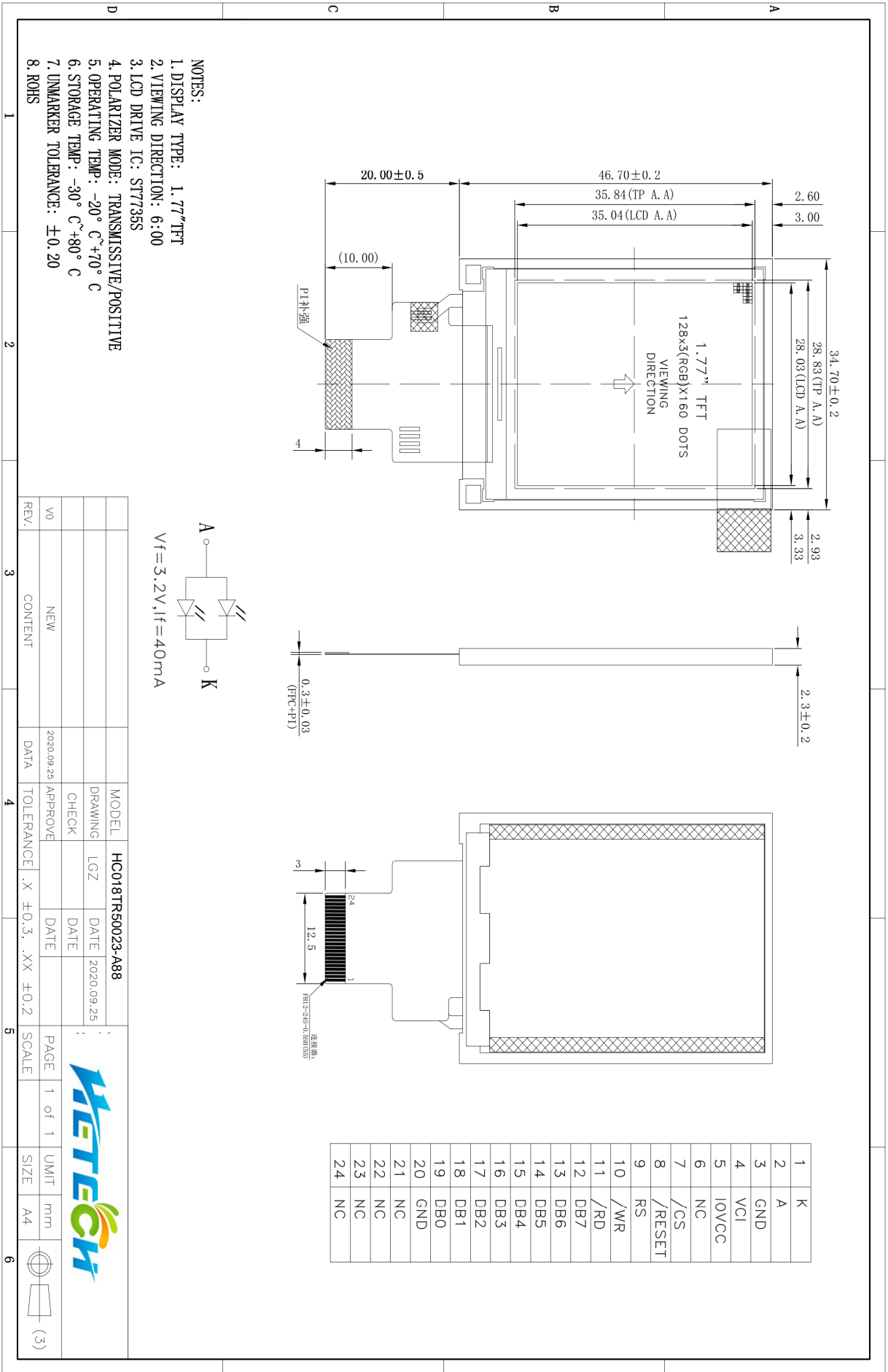

3. Interface Description

PIN NO.	PIN NAME	DESCRIPTION
1	K	LED backlight kathode
2	A	LED backlight anode
3	GND	Power ground
4	VCI	P System power supply.
5	IOVCC	I/O power supply.
6	NC	NC
7	/CS	Chip select signal input terminal, Active at 'L'
8	/RESET	Reset signal input terminal, active at 'L'
9	RS	Register select signal input terminal: RS='H': select a control register; RS='L': select an index or status register.
10	/WR	Write signal input terminal, Active at 'L'
11	/RD	Read signal input terminal, Active at 'L'.
12	DB7	8-bit parallel bi-directional data bus for MPU system.
13	DB6	
14	DB5	
15	DB4	
16	DB3	
17	DB2	
18	DB1	
19	DB0	
20	GND	Power ground
21	YU	NC
22	XL	
23	YD	
24	XR	

4. Absolute Maximum Ratings

Item	Symbol	Min.	Max.	Unit
Logic Supply Voltage	IOVCC	-0.3	4.6	V
Analog Supply Voltage	VCI	-0.3	4.6	V
Input Voltage	Vin	-0.3	IOVCC+0.3	V
Operating Temperature	T _{OP}	-20	70	°C
Storage Temperature	T _{ST}	-30	80	°C
Storage Humidity	HD	20	90	%RH

Signal	Symbol	Parameter	min	max	unit	description
D/CX	tast	Address setup time	0		ns	
	taht	Address hold time(Write/Read)	10		ns	
CSX	tchw	"S""H" Pulse Width	0		ns	
	tcs	Chip Select setup time (Write)	10		ns	
	trcs	Chip Select setup time (Read ID)	45		ns	
	trcsfm	Chip Select setup time (Read FM)	355		ns	
	tcsf	Chip Select Wait time(Write/read)	10		ns	
WRX	twc	Write cycle	60		ns	
	twrh	Control pulse H duration	15		ns	
	twrl	Control pulse L duration	15		ns	
RDX	trc	Read cycle (ID)	160		ns	When read ID
	trdh	Control pulse H duration(ID)	90		ns	data
	trdl	Control pulse L duration(ID)	45		ns	
RDX	trcfm	Read cycle (FM)	450		ns	When read from frame memory
	trdhfm	Control pulse H duration (FM)	90		ns	
	trdlfm	Control pulse L duration (FM)	355		ns	
D[17..0]	tdst	Data setup time	10		ns	For maximum CL = 30pF
	tdht	Data hold time	10		ns	
	trat	Read access time (ID)		40	ns	For minimum CL = 8pF
	tratfm	Read access time (FM)		340	ns	
	toth	Output disable time	20	80	ns	

7. Backlight Characteristics

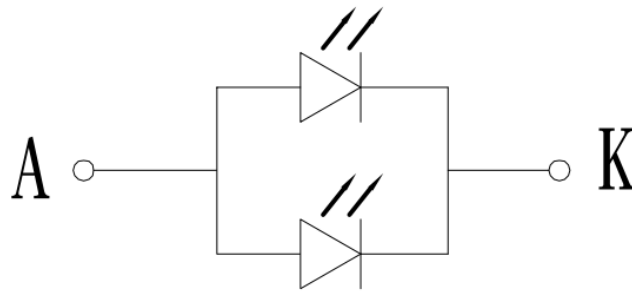

Item	Symbol	MIN	TYP	MAX	UNIT	Test Condition
Supply Voltage	Vf	2.8	3.2	3.4	V	If=40mA
Supply Current	If	-	40	-	mA	-
Luminous Intensity for LCM	-	400	500	-	Cd/m ²	If=40mA
Uniformity for LCM	-	80	-	-	%	If=40mA
Life Time	-	20000	-	-	Hr	If=40mA
Backlight Color	White					

8. Optical Characteristics

(Note1, Note2)

(Using Polarizer+Corresponding Backlight, reference only)

Item	Symbol	Condition	Specification			Unit	Remark
			Min.	Typ.	Max.		
Response time	Tr+Tf	$\theta = 0^\circ$	-	30	60	ms	Note 6
Contrast ratio	CR	$\theta = 0^\circ$	200	300	-		Note 3,7
Viewing angle	Top	$CR \geq 10$	40	45	-	deg.	Note 3,7,8
	Bottom	$CR \geq 10$	15	20	-		
	Left	$CR \geq 10$	40	45	-		
	Right	$CR \geq 10$	40	45	-		
CF Color chromaticity(CIE)	Wx	$\theta = 0^\circ$	-0.02	0.308	+0.02		Note 4
	Wy			0.327			
	Rx			0.610			
	Ry			0.329			
	Gx			0.299			
	Gy			0.567			
	Bx			0.143			
	By			0.111			
Cross talk	ct				2%		Note 10
Transmittance	Trans		6.21%	6.9%	-		Note 5

Note 1. Ambient condition : $25 \pm 2^\circ\text{C}$, $60 \pm 10\%RH$, under 10 Lux in the darkroom .

Note 2. Measure device: BM-5A(TOPCON), viewing cone= 1° , $I_L=20\text{mA}$, after 10 minutes operation.

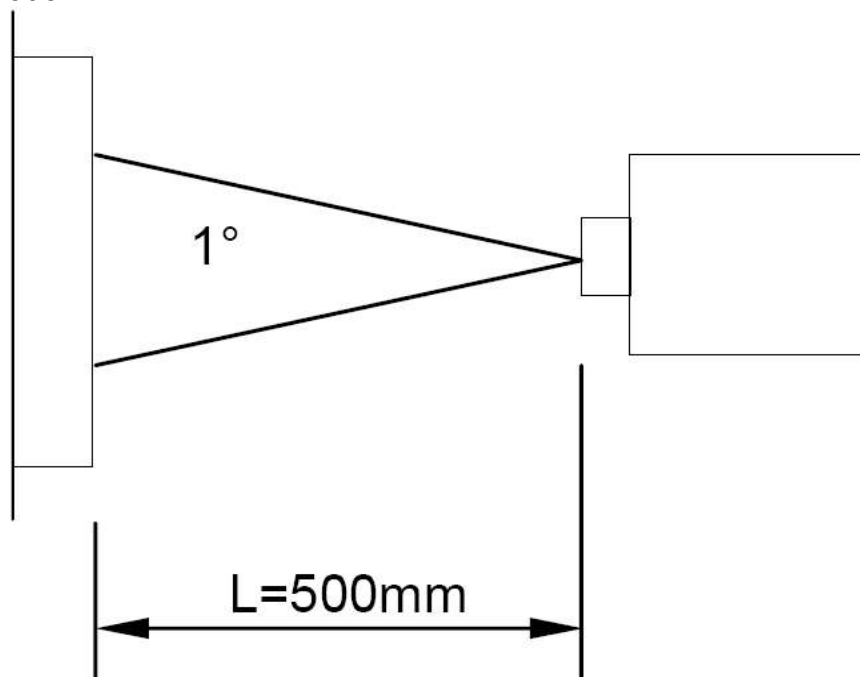

Note 3. Definition of Luminance Uniformity : $L = L(\text{MIN}) / L(\text{MAX}) \times 100\%$

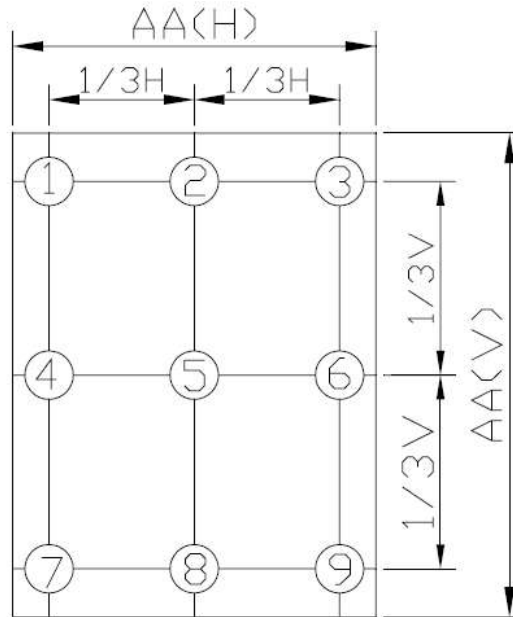

Note 4. Definition of Contrast Ratio :

$$CR = \text{White Luminance (ON)} / \text{Black Luminance (OFF)}$$

Note 5. Definition of response time : The response time is defined as the time interval between the 10% and 90% amplitudes.

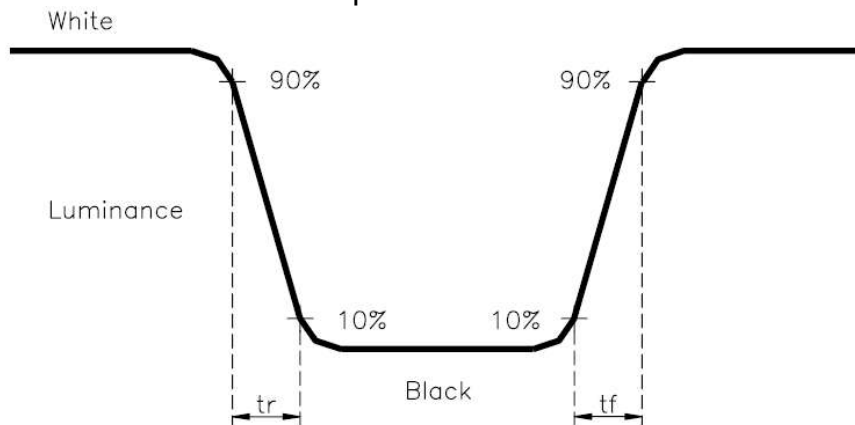

Note 6. Definition of view angle(θ , ψ) :

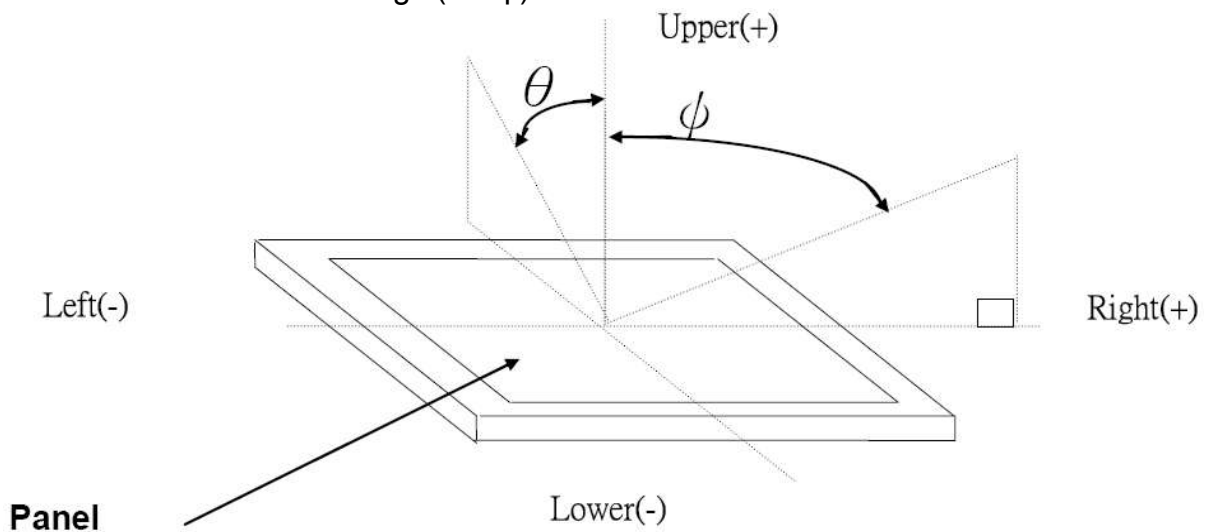

9 . Reliability Test Conditions And Methods

NO.	TEST ITEMS	TEST CONDITION	INSPECTION AFTER TEST
①	High Temperature Storage	80℃±2℃×96Hours	Inspection after 2~4hours storage at room temperature,the samples should be free from defects: 1,Air bubble in the LCD. 2,Sealleak. 3,Non-display. 4,Missing segments. 5,Glass crack. 6,Current IDD is twice higher than initial value. 7,The surface shall be free from damage. 8,The electric charateristic requirements shall be satisfied.
②	Low Temperature Storage	-30℃±2℃×96Hours	
③	High Temperature Operating	70℃±2℃×96Hours	
④	Low Temperature Operating	-20℃±2℃×96Hours	
⑤	Temperature Cycle(Storage)	-20℃ ↔ 25℃ ↔ 70℃ (30min) (5min) (30min) 1cycle Total 10cycle	
⑥	Damp Proof Test (Storage)	50℃±5℃×90%RH×96Hours	
⑦	Vibration Test	Frequency:10Hz~55Hz~10Hz Amplitude:1.5M X,Y,Z direction for total 3hours (Packing Condition)	
⑧	Drooping Test	Drop to the ground from 1M height one time every side of carton. (Packing Condition)	
⑨	ESD Test	Voltage:±8KV,R:330Ω,C:150PF,Air Mode,10times	

REMARK:

- 1,The Test samples should be applied to only one test item.
- 2,Sample side for each test item is 5~10pcs.
- 3,For Damp Proof Test,Pure water(Resistance > 10MΩ)should be used.
- 4,In case of malfunction defect caused by ESD damage,if it would be recovered to normal state after resetting,it would be judge as a good part.
- 5,EL evaluation should be excepted from reliability test with humidity and temperature:Some defects such as black spot/blemish can happen by natural chemical reaction with humidity and Fluorescence EL has.
- 6,Failure Judgment Criterion:Basic Specification Electrical Characteristic,Mechanical Characteristic,Optical Characteristic.

10. Inspection Standard

This standard apply to C-STN/TFT module

1. Spot check plan:

According to spot check level II ,MIL-STD-105E Level II ,the rank of accept or reject is below:

A 级: major non-conformance: AQL 0.65 minor non-conformance: AQL 1.

2. Inspection condition:

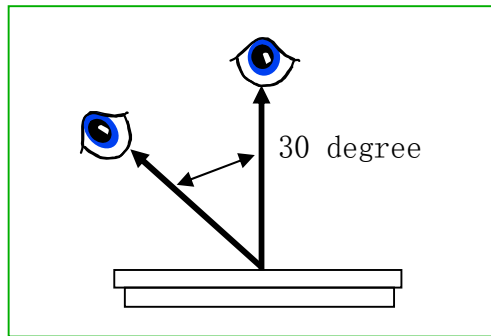

Under daylight lamp 20~40W, product distance inspector'eye 30cm,incline degree 30°.

3. LCD area define:

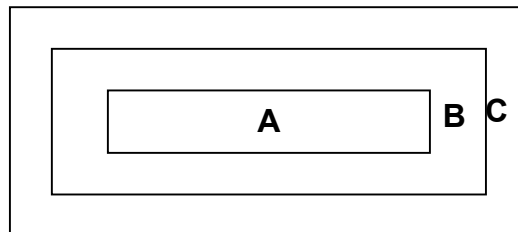

Area A: display area

Area B: VA area

Area C: out of VA area,not in sight after assembly

Remark :non-conformance at area C,but is OK that isn't influence raliability of product & assembly by customer.

4. Inspection standard

4.1 Major non-conformance

NO.	Item	Inspection standard	Rate
4.1.1	Function non-conformance	1) No display, display abnormaly 2) Miss line, short 3) B/L no function or function abnormaly 4) TP no function	major
4.1.2	miss	No matter miss what component	
4.1.3	Out of size	Module dimension out of spec	

4.2 Appearance non-conformance

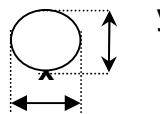
NO.	Item	Inspection standard	Rate																														
4.2.1	Black or white spot (power on)	dot non-conformance define Φ $\Phi = \frac{(x+y)}{2}$ 	Minor																														
		A grade <table border="1"> <thead> <tr> <th rowspan="2">area size (mm)</th> <th colspan="3">Most approve q'ty</th> </tr> <tr> <th>A</th> <th>B</th> <th>C</th> </tr> </thead> <tbody> <tr> <td>$\Phi \leq 0.10$</td> <td colspan="3">ignore</td> </tr> <tr> <td>$0.10 < \Phi \leq 0.15$</td> <td>3</td> <td colspan="2" rowspan="3">ignore</td> </tr> <tr> <td>$0.15 < \Phi \leq 0.20$</td> <td>2</td> </tr> <tr> <td>$0.20 < \Phi \leq 0.25$</td> <td>1</td> </tr> <tr> <td>$0.25 < \Phi$</td> <td>0</td> <td colspan="2"></td> </tr> </tbody> </table> <p>Most approve 4 damages, dot to dot $\geq 10\text{mm}$</p>		area size (mm)	Most approve q'ty			A	B	C	$\Phi \leq 0.10$	ignore			$0.10 < \Phi \leq 0.15$	3	ignore		$0.15 < \Phi \leq 0.20$	2	$0.20 < \Phi \leq 0.25$	1	$0.25 < \Phi$	0									
area size (mm)	Most approve q'ty																																
	A	B	C																														
$\Phi \leq 0.10$	ignore																																
$0.10 < \Phi \leq 0.15$	3	ignore																															
$0.15 < \Phi \leq 0.20$	2																																
$0.20 < \Phi \leq 0.25$	1																																
$0.25 < \Phi$	0																																
4.2.2	Black or white line (power on)	A grade <table border="1"> <thead> <tr> <th colspan="2">Size(mm)</th> <th colspan="3">Most approve q'ty</th> </tr> <tr> <th>L(length)</th> <th>W(width)</th> <th>A</th> <th>B</th> <th>C</th> </tr> </thead> <tbody> <tr> <td>ignore</td> <td>$W \leq 0.03$</td> <td colspan="3">ignore</td> </tr> <tr> <td>$L \leq 5.0$</td> <td>$0.03 < W \leq 0.05$</td> <td colspan="3">2</td> </tr> <tr> <td>$L \leq 3.0$</td> <td>$0.05 < W \leq 0.07$</td> <td colspan="3">1</td> </tr> <tr> <td></td> <td>$0.07 < W$</td> <td colspan="3">Treat with dot non-conformance</td> </tr> </tbody> </table> <p>Most approve 3 damages, line to line $\geq 10\text{mm}$</p>	Size(mm)		Most approve q'ty			L(length)	W(width)	A	B	C	ignore	$W \leq 0.03$	ignore			$L \leq 5.0$	$0.03 < W \leq 0.05$	2			$L \leq 3.0$	$0.05 < W \leq 0.07$	1				$0.07 < W$	Treat with dot non-conformance			Minor
		Size(mm)		Most approve q'ty																													
L(length)	W(width)	A	B	C																													
ignore	$W \leq 0.03$	ignore																															
$L \leq 5.0$	$0.03 < W \leq 0.05$	2																															
$L \leq 3.0$	$0.05 < W \leq 0.07$	1																															
	$0.07 < W$	Treat with dot non-conformance																															
4.2.3	Polarizer position	1) polarizer attach meet drawing, disallow out of LCD. 2) polarizer must cover display area (special require unless)	Minor																														

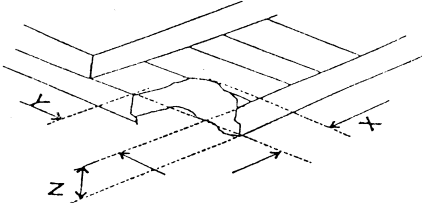
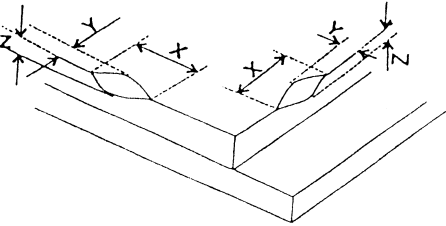
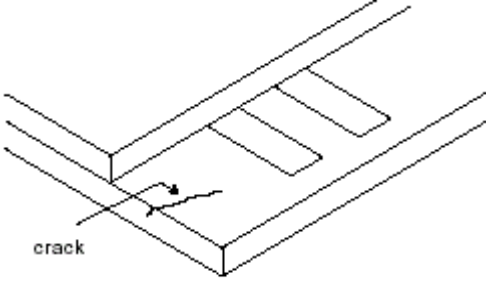
4.2.4	LCD non-conformance	<p>(i) crash at side (remark: S=ITO length)</p>  <table border="1" data-bbox="555 425 1189 521"> <thead> <tr> <th>X</th> <th>Y</th> <th>Z</th> </tr> </thead> <tbody> <tr> <td>≤3.0</td> <td>≤S</td> <td>ignore</td> </tr> </tbody> </table> <p>Crash disallow extend to ITO or seal.</p>	X	Y	Z	≤3.0	≤S	ignore	Minor	
		X	Y	Z						
		≤3.0	≤S	ignore						
<p>(ii) commonly surface scathe</p>  <table border="1" data-bbox="534 862 1209 958"> <thead> <tr> <th>X</th> <th>Y</th> <th>Z</th> </tr> </thead> <tbody> <tr> <td>≤2.0</td> <td><frame edge</td> <td>ignore</td> </tr> </tbody> </table>	X	Y	Z	≤2.0	<frame edge	ignore				
X	Y	Z								
≤2.0	<frame edge	ignore								
<p>(iii) crack Disallow extend crack</p> 										
4.2.5	Contrast voltage arp	VOP/Vlcd voltage of confirmed sample ±0.15V	Minor							
4.2.6	color	Color & luminance of module scope reference spec	Minor							
4.2.7	Cross talk	Reference confirmed limit sample	Minor							

11. Handling Precautions

11.1 Mounting method

The LCD panel consists of two thin glass plates with polarizers which could easily be damaged. And since the module is so constructed as to be fixed by utilizing fitting holes in the printed circuit board.

Extreme care should be needed when handling the LCD modules.

11.2 Caution of LCD handling and cleaning

When cleaning the display surface, Use soft cloth with solvent [recommended below] and wipe lightly

- Isopropyl alcohol
- Ethyl alcohol

Do not wipe the display surface with dry or hard materials that will damage the polarizer surface.

Do not use the following solvent:

- Water
- Aromatics

Do not wipe ITO pad area with the dry or hard materials that will damage the ITO patterns

Do not use the following solvent on the pad or prevent it from being contaminated:

- Soldering flux
- Chlorine (Cl), Sulfur (S)

If goods were sent without being silicon coated on the pad, ITO patterns could be damaged due to the corrosion as time goes on.

If ITO corrosion happens by miss-handling or using some materials such as Chlorine (Cl), Sulfur (S) from customer, Responsibility is on customer.

11.3 Caution against static charge

The LCD module uses C-MOS LSI drivers, so we recommend that you:

Connect any unused input terminal to VDD or VSS, do not input any signals before power is turned on, and ground your body, work/assembly areas, assembly equipment to protect against static electricity.

11.4 Packing

- Module employs LCD elements and must be treated as such.
- Avoid intense shock and falls from a height.
- To prevent modules from degradation, do not operate or store them exposed directly to sunshine or high temperature/humidity

11.5 Caution for operation

- It is an indispensable condition to drive LCD's within the specified voltage limit since the higher voltage than the limit causes the shorter LCD life.
- An electrochemical reaction due to direct current causes LCD's undesirable deterioration, so that the use of direct current drive should be avoided.
- Response time will be extremely delayed at lower temperature than the operating temperature range and on the other hand at higher temperature LCD's show dark color in them. However those phenomena do not mean malfunction or out of order with LCD's, which will come back in the specified operation temperature.
- If the display area is pushed hard during operation, some font will be abnormally displayed but it resumes normal condition after turning off once.
- A slight dew depositing on terminals is a cause for electro-chemical reaction resulting in terminal open circuit.

Usage under the maximum operating temperature, 50%RH or less is required.

11.6 storage

In the case of storing for a long period of time for instance, for years for the purpose or replacement use, the following ways are recommended.

- Storage in a polyethylene bag with the opening sealed so as not to enter fresh air outside in it .
And with no desiccant.
- Placing in a dark place where neither exposure to direct sunlight nor light's keeping the storage temperature range.
- Storing with no touch on polarizer surface by the anything else.
[It is recommended to store them as they have been contained in the inner container at the time of delivery from us

11.7 Safety

- It is recommendable to crash damaged or unnecessary LCD's into pieces and wash off liquid crystal by either of solvents such as acetone and ethanol, which should be burned up later.
- When any liquid leaked out of a damaged glass cell comes in contact with your hands, please wash it off well with soap and water

12. Precaution For Use

12.1

A limit sample should be provided by the both parties on an occasion when the both parties agreed its necessity. Judgment by a limit sample shall take effect after the limit sample has been established and confirmed by the both parties.

12.2

On the following occasions, the handing of problem should be decided through discussion and agreement between responsible of the both parties.

- When a question is arisen in this specification
- When a new problem is arisen which is not specified in this specifications
- When an inspection specifications change or operating condition change in customer is reported to LCD , and some problem is arisen in this specification due to the change
- When a new problem is arisen at the customer's operating set for sample evaluation in the customer site.

13. Packing Method

